

AC CURTAIN MOTOR

Fitting & Operating Instructions



KEY FEATURES

- Hard wired AC100-240V motor, the wider voltage range means the motor can operate in areas/ countries with different power outputs.
- The system can be operated using a remote, the smart controller or manual operation.
- Flexible system with smooth operation and quiet design, featuring soft stop and start.
- Suitable for many installations.
- In the event of a power outage the curtain can still be manually operated.
- Manual Motorised: The curtain can be gently pulled a short distance from one side to trigger the automatic open/close function of the curtain.
- Automatic set-up: The motor will automatically set the limits of the curtain on the first operation and store the settings. Power failure will not affect the memory settings.
- If the curtain carriers meet any form of resistance during operation the curtain will stop automatically to protect the system.

PARAMETERS

Model No.	CS2030-AC
Rated Torque	1.2Nm
Speed	12CM/S
Housing Size	295x50x50mm
Rated Voltage	100~240V AC 50/60Hz
Rated Power	40W
IP Level	IP20

LOADING DIAGRAM

	Split Draw Curtain	One-way Draw Curtain
Curtain Size 117cm Curtain	Pole Size (cm)	
	178cm	110cm
	Max Weight Added (kg)	
	13.50 kg	4.50kg
Curtain Size 168cm Curtain	Pole Size (cm)	
	228cm	122cm
	Max Weight Added (kg)	
	13.50kg	7.65kg
Curtain Size 229cm Curtain	Pole Size (cm)	
	277cm	147cm
	Max Weight Added (kg)	
	13.50kg	9.45kg
Curtain Size 258cm Curtain	Pole Size (cm)	
	500cm	245cm
	Max Weight Added (kg)	
	13.50kg	13kg
Curtain Size 284cm Curtain	Pole Size (cm)	
	500cm	270cm
	Max Weight Added (kg)	
	13.50kg	13kg

We recommend the use of Pan Head Screws when fixing brackets. Maximum 12 Eyelets Per Curtain.

COMPONENTS

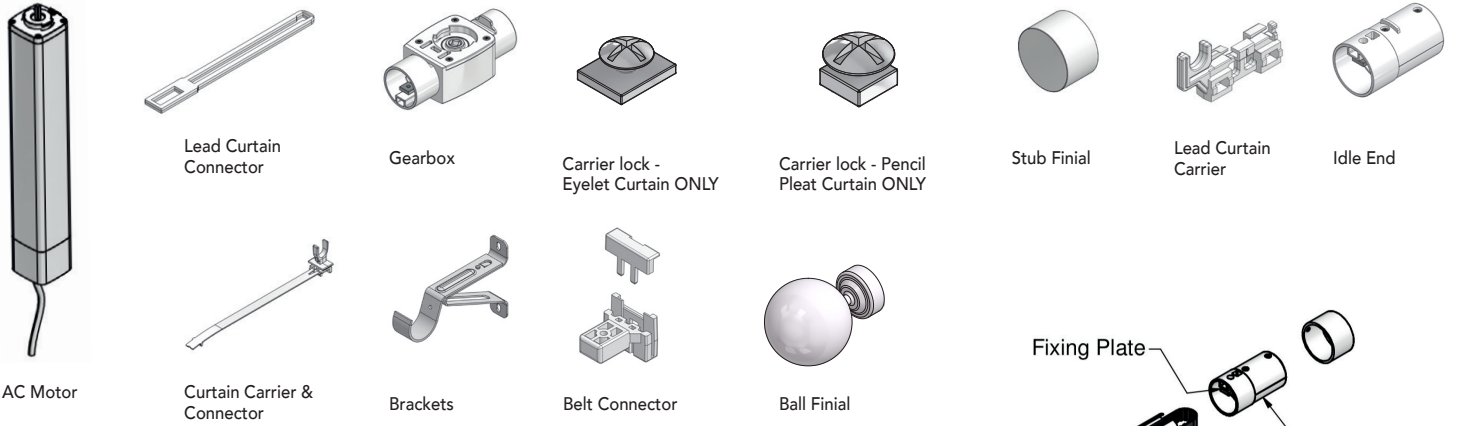

MOTOR ASSEMBLY

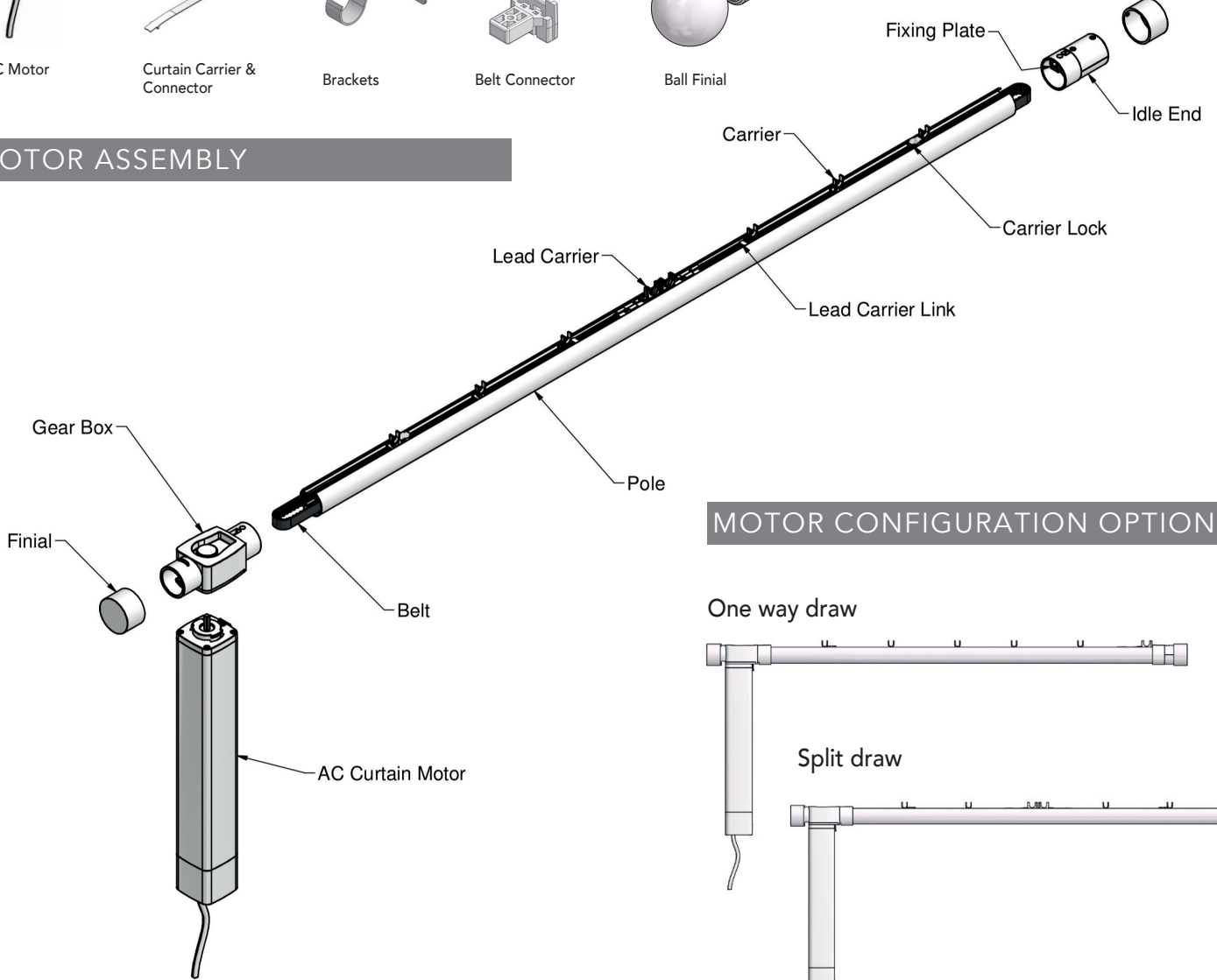

MOTOR CONFIGURATION OPTIONS

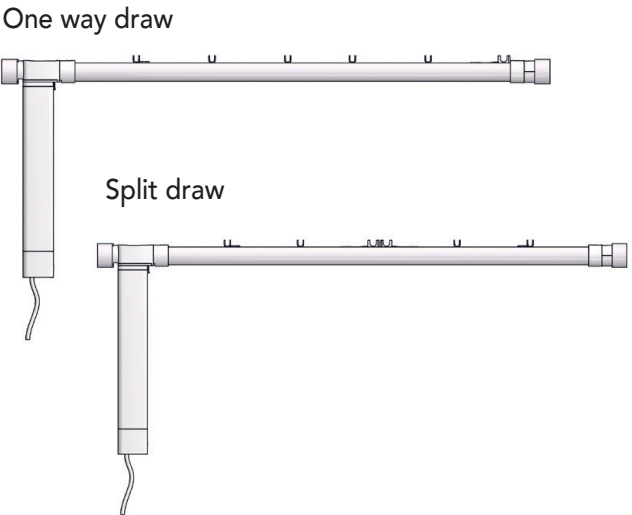

MOTOR INSTALLATION

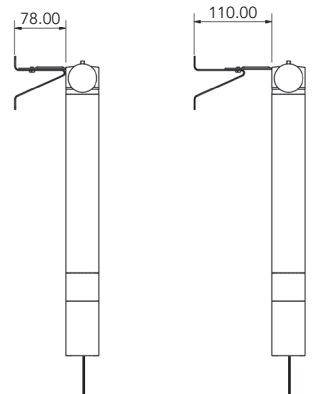
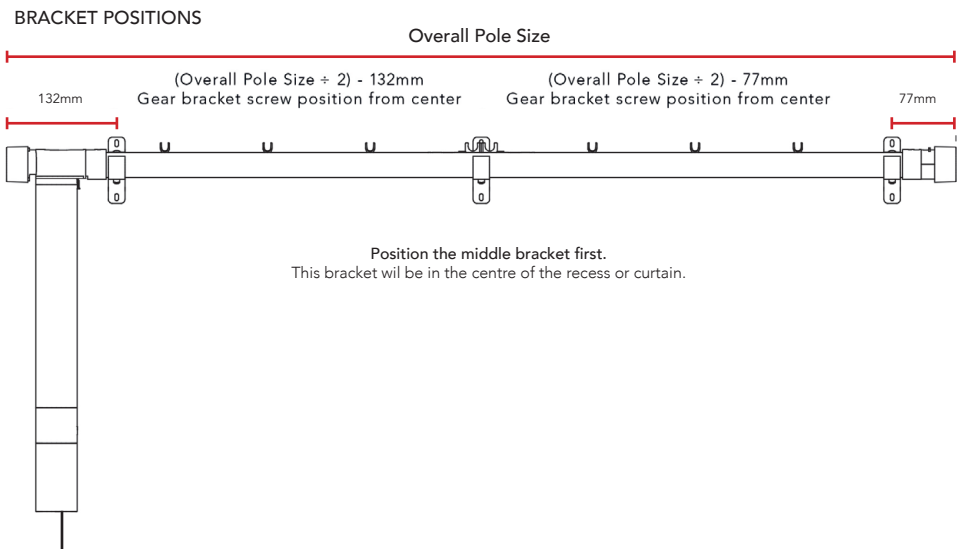

MOTOR INSTALLATION

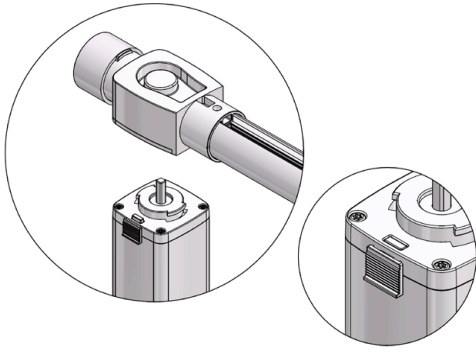

Step 1 - Line up motor and press down lock bar.

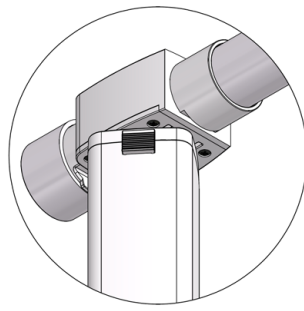

Step 2 - Insert Motor and Twist.

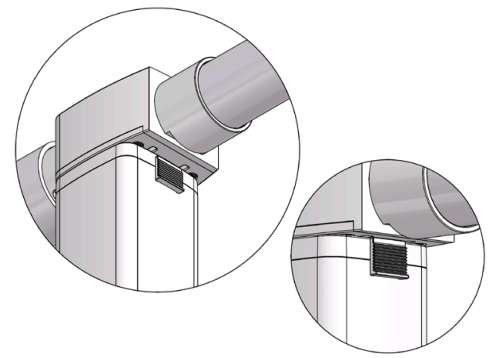

Step 3 - Release the lock bar and make sure it is in the stop position.

UNINSTALLING THE MOTOR

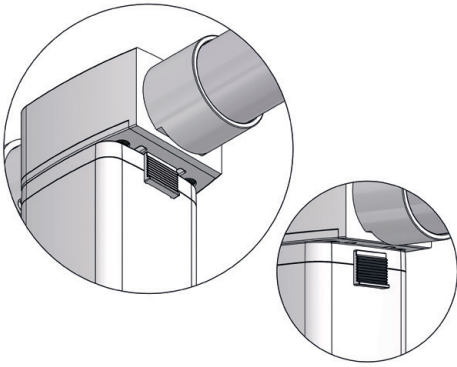

Step 1 - Pull the lock bar down to release from stop position.

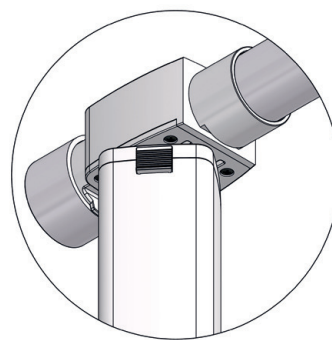

Step 2 - Twist to remove motor.

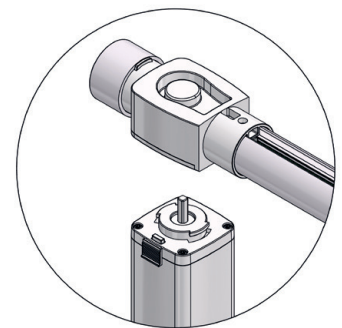

Step 3 - Release Motor

OPERATING INSTRUCTIONS

1 ENTER PROGRAMMING MODE

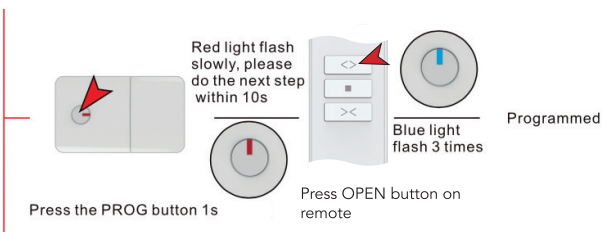

Please select channel for multi-channel remote before operation as 0.5 seconds is needed for up/down converting, max single running time is 4min.

2 CHANGE DIRECTION

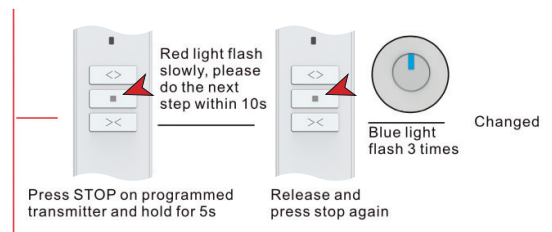

3 PAIR REMOTE

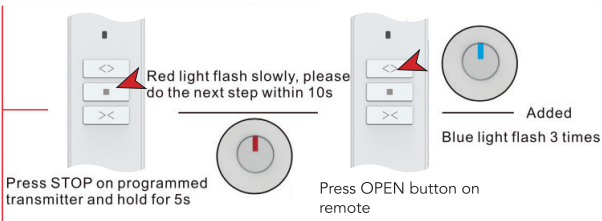

4 DELETE SINGLE CHANNEL

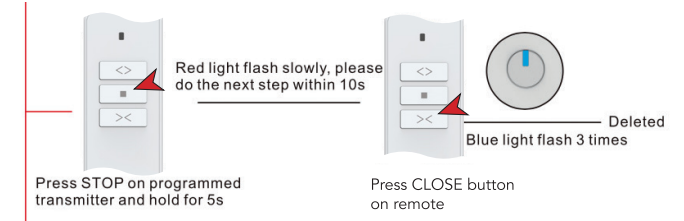

5 DELETE ALL CHANNELS

* Channels will be deleted and the motor direction will be reset to factory default mode, keeping the touch function.

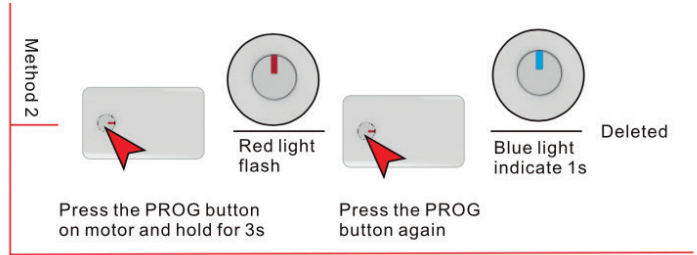
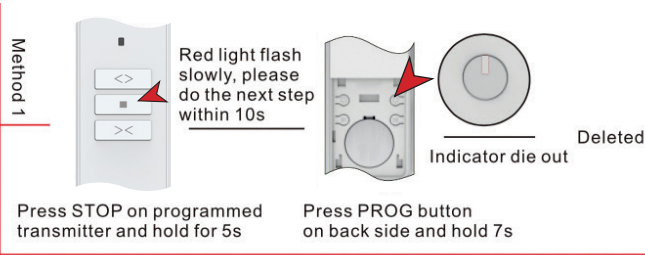

6 BLUETOOTH SETTING MODE

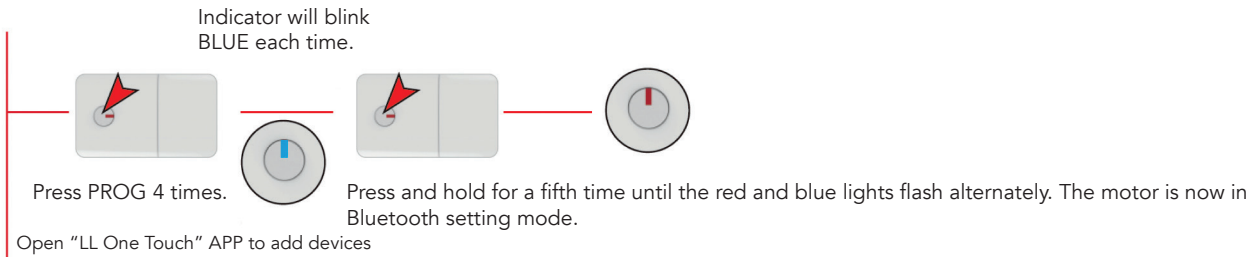

7 MANUAL CONTROL FUNCTION

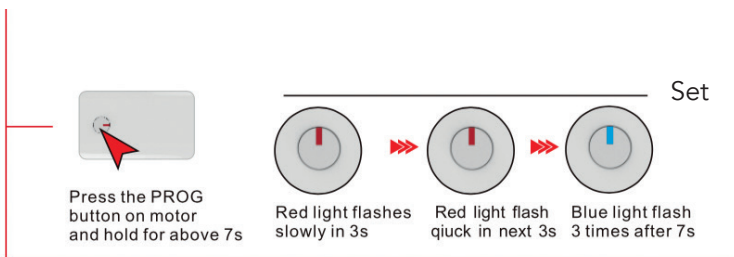

8 MANUAL MOTORIZED FUNCTION

Method 1

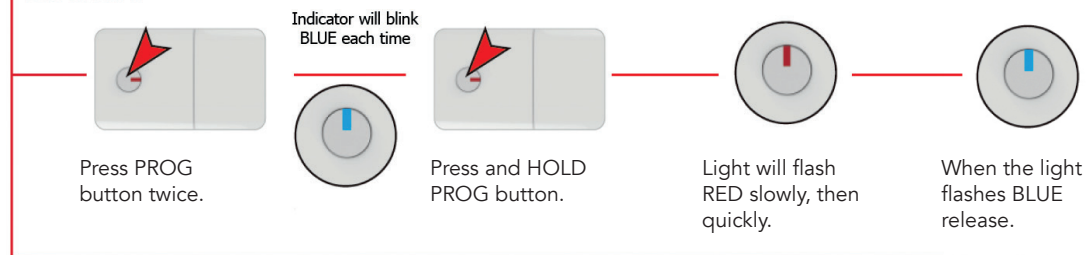

FAQ	SOLUTION
Power on, but motor not responding	Check the motor battery is fully charged. Check remote battery. Check remote is paired.
Motor is working but curtain is not moving	Check the curtain track is assembled correctly.
Motor works automatically	Delete all remotes, program again.
Can't pull curtain manually	1. Pull the curtain backwards, then pull forwards again. 2. Pull the curtain position back 10cm. 3. Charge motor.