

LOUVOLITE



URBAN
SHUTTERS
TRAINING PROGRAMME

TRAINING PROGRAMME

Why choose Urban Shutters

Features of Urban Shutters

Frame options

Panel opening options

Survey sheet

PRACTICAL TRAINING

How to measure

Measuring tools

Measuring of square windows
(inside & outside)

Measuring bay windows

Common obstructions

Options on gap filling

Component dimensions

Shutter assembly (demo)

Shutter installation (demo)

Cleaning maintenance and
repair (demo)

Q&A

URBAN SHUTTERS



WHY CHOOSE URBAN SHUTTERS

CUSTOM MADE

Your shutters will be custom made in the UK to your exact specifications. They are designed to give an elegant appearance with the ultra strong polysilk vinyl creating a sturdy and long lasting window dressing that will not chip, crack or peel. Our high-tech, computerised manufacturing facilities ensure that all the louvres are equidistantly spaced to achieve the perfect aesthetic balance.

STAY LOOKING GOOD

The durability of Urban Shutters makes them ideal for today's busy lifestyles. They will never require painting or staining as the colour is embedded into the shutter itself. Everyday scratches and dents do not affect the finish or colour - minor scratches can simply be sanded out. Individual louvres can even be replaced – just snap out the old louvre and clip in a new one.

OUTSTANDING STRENGTH

The operating system uses unique Louvrelink connectors that are hard wearing and allow the louvres to close together in both directions giving you enhanced privacy. Using Louvrelink connectors means we don't need to use staples.

WATER-RESISTANT

Urban Shutters resist the damaging effects of moisture due to their polysilk vinyl making them the perfect choice for wet or humid environments such as kitchens and bathrooms.

COORDINATE WITH YOUR INTERIOR STYLE

You can enhance all interiors by choosing from a wide variety of decorative frames for inside and outside mounts.

PERSONAL STYLE

Choose from either 63mm or 89mm louvre sizes in Cotton White or Arctic White allowing you to create the perfect look.

The upper and lower rail sections are available in two sizes, 50mm or 100mm, giving you the opportunity to further style your shutter.

INSULATION FOR YOUR HOME

Urban Shutters help reduce outside noise and keep heating and air conditioning costs down with their excellent insulating properties due to the robust cell structure of the frames and louvres.

ADVANCED LIGHT CONTROL

The unique 'Duplex' feature on the tilt bar allows ultimate control of the balance between light and privacy for your room. Duplex allows the top louvres to remain open allowing in light whilst the bottom louvres remain closed for privacy.

LOOKING NEAT

The spring loaded, self-levelling feature ensures that the panels remain level whilst closed.

FLAME RETARDANT

All our Urban Shutters are flame retardant to UK standards so they are ideal for use in both commercial or domestic environments.

EASY TO CLEAN

Your shutters are easy to clean with soap and lukewarm water. Regular cleaning enhances the surface finish of the polysilk vinyl.

HELP PROTECT THE ENVIRONMENT

Urban Shutters are environmentally friendly. They meet all regulations relating to the emission of organic compounds and are 100% recyclable which means no waste management issues.

KEEP CHILDREN SAFE

Urban Shutters contain no cords which could be harmful to a child.

QUICK TURNAROUND

Your shutters will be custom made at our UK manufacturing plant. This means that the whole process, from initial consultation right through to delivery and fitting of your shutters, can all be done more quickly and efficiently. We are also on hand to answer any queries you may have along the way.

SATISFACTION GUARANTEED

Our Urban Shutter range comes with a 10 year warranty.*

URBAN
SHUTTERS

FEATURES OF URBAN SHUTTERS

SHUTTER ASSEMBLY

The basic shutter assembly is a shutter panel hinged to a frame. The panel consists of louvres which pivot open and closed, with stiles on the sides and rails on the top and bottom. Panels over 2200mm in height require at least one divider rail.



PANEL COMPONENTS

Concealed stile caps serve the same function on the top and bottom of the stiles and provide a more finished look to the panels. The Astragal is a flange to block the light gap where two shutter panels meet. It is not needed in single panel assemblies.

LOUVRES

Vented louvres are available in two sizes 63mm, 89mm and come in two colours Cotton White or Arctic White.



LOUVRELINK SYSTEM

The shutter louvres are opened and closed using a tilt bar linked to the louvres with our unique Louvrelink system.

The tilt bar can be ordered on the front hinge side or rear hinge side of the panel.

DIVIDER RAILS

With a divider rail in place, the separate sections of the panel operate independently of each other.

A divider rail is required for all single panels greater than 2200mm in height.

SPRING CATCH

The Spring Catch system comes as standard and is also adjustable using a small flat head screwdriver.



T-POST

The T-Post is a versatile structural component inserted vertically into shutter frames to separate shutter sections and allow for placement of more panels within the same opening. T-Posts give added strength to wider openings. Panels can be hinged to T-Posts similarly as to how they are hinged to the frame. The T-Posts enable the consumer to custom design their own openings.

TRANSOM BEAM

A transom beam can be added for extra support where a Tier on Tier application is required. The Transom beam can only be used with the Magnetic Catch.

FRAME OPTIONS

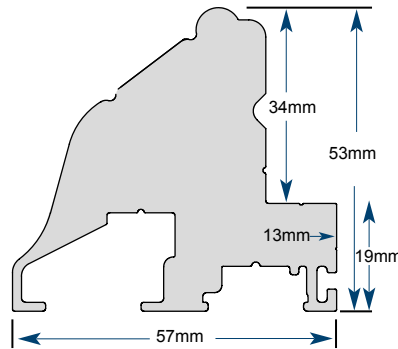

CLASSIC FRAME

- Mounting Type: Outside mount only.
- Overall Depth: 53mm.
- Overall Width: 57mm.

FEATURES: An outside mount frame designed to be installed directly onto the wall surrounding the window or on top of existing trim surrounding the window.

FEATURES: Can be used with buildout 12.7mm or 25.4mm.

CLASSIC FRAME

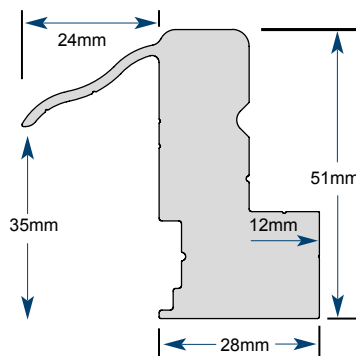

CONTEMPO MAXI Z FRAME

- Mounting type: Inside mount only.
- Overall Depth: 51mm.
- Overall Width: 52mm.

FEATURES: An inside mount frame to be installed directly into the window opening. The face of the frame acts as a decorative cover that hides out-of-square areas. Sill plate option available.

CONTEMPO MAXI Z FRAME

FRAME OPTIONS

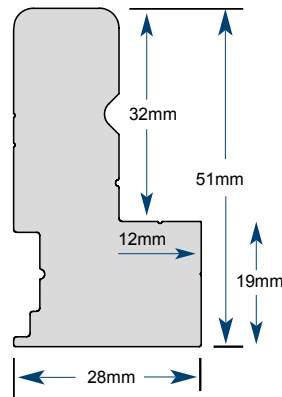

MODA L FRAME

- Mounting Type: Inside mount only.
- Overall Depth: 51mm.
- Overall Width: 28mm.

FEATURES: An inside mount frame to be installed directly into the window opening.

MODA L FRAME

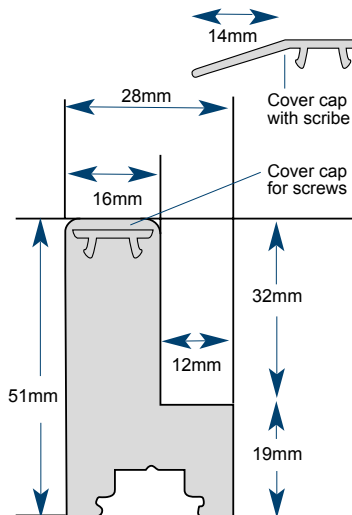

MODA MULTI L FRAME

- Mounting type: Inside or outside mount.
- Overall Depth: 51mm.
- Overall Width: 28mm.

FEATURES: Can be used with buildout 12.7mm or 25.4mm and flexible cover cap with scribe.

Best option for Bay Windows.

MODA MULTI L FRAME

PANEL OPENING OPTIONS

FULL HEIGHT

WITH 50mm RAIL



With the full height option, the panel covers the full window with no divider rail.

FULL HEIGHT

100mm RAIL WITH DIVIDER RAIL



Adding a divider rail means you can independently control the louvre direction on both the top and bottom sections.

FULL HEIGHT

CONCEALED TILT BAR



Concealing the tilt bar enhances the shutter's clean lines for the ultimate in sophistication. You can control the shutters by simply turning the louvers.

FULL HEIGHT

DUPLEX



Duplex sections the shutter into groups of louvres. The groups can move independently, allowing additional control over different levels of light and privacy.

PANEL OPTIONS

TIER ON TIER

WITH TRANSOM



TIER ON TIER

WITHOUT TRANSOM



CAFÉ STYLE

THREE SIDED FRAME



CAFÉ STYLE

FOUR SIDED FRAME



Tier on Tier shutters consist of two separate panels that move independently. An ideal solution to easily access upper windows whilst maintaining privacy in the lower section.

Tier on Tier max width: 1600mm (max two panel wide).

Café style shutters are panels that cover a section of the window allowing in additional light while retaining some privacy.

A four sided frame is required for Café style shutters when used in bay windows.

PLEASE NOTE:

- The shutter and frame will not create a total blackout unit.
- Please be aware that on bi-fold or multi-fold configurations, panels can drop when opened and will require lifting when closing.
- All shutters require a 4 sided frame - except Café style.

PANEL OPTIONS (Including T-Posts)

Example Configuration

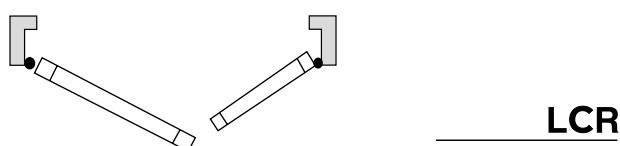
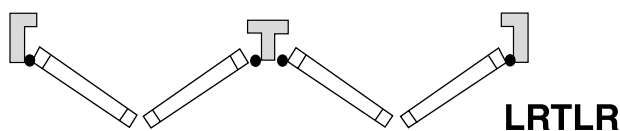
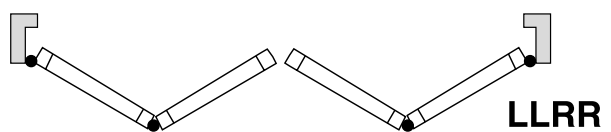
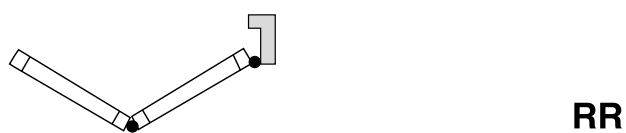
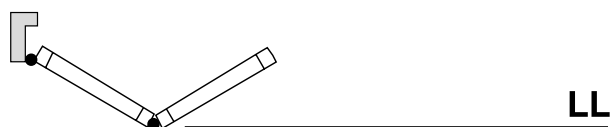
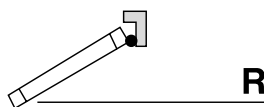
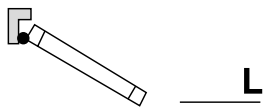

PANEL CONFIGURATION

- L = Left Hinge
- R = Right Hinge
- LL = Left Bi-fold
- RR = Right Bi-fold
- LLRR = 4 Panel Bi-fold
- LRTLRL = Panel T-post

Print the letters of the Bi-Fold panel configuration.

T-POST

T = T-Post is placed to provide equally divided openings for uneven placement, always start from the left, indicate distance in mm from left side of shutter to centre of each T-Post (show on diagram).

CUSTOM PANEL SPLIT

(Indicated by C)

C split can only be between L-R and is used to indicate uneven panel sizes.

Eg: C can not be between:

2xL / 3xL

2xR / 3xR

Measurements for C:

Taken from left wall to panel split position, C can also be used in conjunction with T-Post.

HINGED SHUTTER SPECIFICATION PANEL SIZES

LOUVRE SIZES	WIDTH				HEIGHT			
	MIN	MAX	MAX	MAX	50mm RAILS		100mm RAILS	
		SINGLE HUNG	BI FOLD	MULTI FOLD	MIN	MAX	MIN	MAX
63mm	150mm	800mm	800mm	700mm	180mm	3000mm	290mm	3000mm
89mm	150mm	900mm	800mm	700mm	200mm	3000mm	310mm	3000mm

Panels must be equal dimensions

PLEASE NOTE: If the Shutter is over 2200mm a divider will be added to the centre unless position (height) is specified.

URBAN
SHUTTERS

Account Number: _____
 Company Name: _____

URBAN SHUTTERS

1. TILT BAR

FRONT HINGE BACK HINGE

Order Date _____

Reference No: _____ C/M Date: _____

Installer: _____

Location:	Blind N°:
Location:	Blind N°:
Width _____mm	Height _____mm
Width _____mm	Height _____mm

<p>2. Qty <input type="text"/></p> <p>3. Colour <input type="text"/></p> <p>4. Panel Across <input type="text"/></p> <p>5. Louvre Size <input type="checkbox"/> 63mm <input type="checkbox"/> 89mm</p> <p>6. Frame Style <input type="text"/></p> <p>7. Frame Application <input type="text"/></p> <p>8. Panel Configuration <input type="text"/></p> <p>9. N° of T-Posts</p> <p>1. <input type="text"/> 2. <input type="text"/> 3. <input type="text"/></p> <p>10. Tier on Tier with Transom <input type="text"/></p> <p>11. Divider Rail without Transom <input type="text"/></p> <p>12. Duplex Tilt Bar</p> <p>1st <input type="text"/> 2nd <input type="text"/></p>	<p>2. Qty <input type="text"/></p> <p>3. Colour <input type="text"/></p> <p>4. Panel Across <input type="text"/></p> <p>5. Louvre Size <input type="checkbox"/> 63mm <input type="checkbox"/> 89mm</p> <p>6. Frame Style <input type="text"/></p> <p>7. Frame Application <input type="text"/></p> <p>8. Panel Configuration <input type="text"/></p> <p>9. N° of T-Posts</p> <p>1. <input type="text"/> 2. <input type="text"/> 3. <input type="text"/></p> <p>10. Tier on Tier with Transom <input type="text"/></p> <p>11. Divider Rail without Transom <input type="text"/></p> <p>12. Duplex Tilt Bar</p> <p>1st <input type="text"/> 2nd <input type="text"/></p>
<p>13. Rails <input type="checkbox"/> 50 <input type="checkbox"/> 100</p> <p>14. Astragal <input type="checkbox"/> Right - Standard <input type="checkbox"/> Left - Optional</p> <p>15. Buildout <input type="checkbox"/> 12 <input type="checkbox"/> 25 <input type="checkbox"/> 37</p> <p>16. Closing System <input type="checkbox"/> Spring Catch (Standard) <input type="checkbox"/> Magnetic</p> <p>17. Special Instructions:</p>	<p>13. Rails <input type="checkbox"/> 50 <input type="checkbox"/> 100</p> <p>14. Astragal <input type="checkbox"/> Right - Standard <input type="checkbox"/> Left - Optional</p> <p>15. Buildout <input type="checkbox"/> 12 <input type="checkbox"/> 25 <input type="checkbox"/> 37</p> <p>16. Closing System <input type="checkbox"/> Spring Catch (Standard) <input type="checkbox"/> Magnetic</p> <p>17. Special Instructions:</p>

Signature Required _____	Signature Required _____
---------------------------------	---------------------------------

URBAN SHUTTERS

ORDER FORM REFERENCE

1. TILT BAR

- Front Hinge Side
- Back Hinge Side

2. NUMBER OF SHUTTERS

3. COLOURS

- Arctic
- Cotton

4. NUMBER OF PANELS

- 1 Panel, 2 Panels, 3 Panels etc...

5. LOUVRE SIZE

- 63mm
- 89mm

6. FRAME STYLES

OUTSIDE MOUNT FRAMES

- Classic Frame

INSIDE MOUNT FRAMES

- Moda L Frame
- Moda Mini L Frame
- Contempo Maxi Z Frame
- Contempo Mini Z Frame
- Contempo Micro Z Frame

INSIDE OR OUTSIDE MOUNT FRAMES

- Moda Multi L Frame

7. FRAME APPLICATIONS

- 3 Sided, no top
- 4 Sided (standard)
- 4SIL = 4 Sided with sillmount (no flange)

8. PANEL CONFIGURATION

- L = Left Hinge
- R = Right Hinge
- LL = Left Bi-Fold
- RR = Right Bi-Fold
- LLRR = 4 Panel Bi-Fold
- LRTL = Panel T-Post

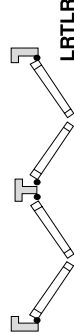
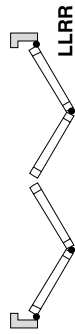
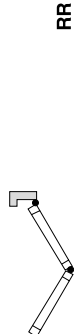
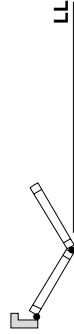
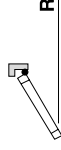

Print the letters of the Bi-Fold panel configuration.

Other panel configurations available on request.

9. T-POST

T-Post is placed to provide equally divided openings. For uneven placement, always start on the left and indicate distance in millimetres from the left side of the shutter to the centre of each T-Post.

10. TRANSOM BEAM

Transom is placed to provide equally divided openings to the top and bottom as standard. If there are any variations, measure from bottom of frame to the centre of transoms.

If no Transom measure from the bottom for split height.

11. DIVIDER RAIL IN PANEL

First divider rail (required over 2200mm in panel height). The standard is the divider rail in the centre of the panel. For custom divider rail measure from bottom of frame to centre divider rail.

12. DUPLEX TILT BAR LOCATION

1st split enter distance from the bottom of the frame to split.

2nd split enter distance from the bottom of the frame to split.

13. RAIL SIZE

PLEASE NOTE: That these can not be mixed.

- 50mm
- 100mm

14. ASTRAGAL

- Right panel over left
- Left panel over right

PLEASE NOTE: Standard Astragal configuration is right panel over left.

15. BUILDOUT

- 12mm buildout extension.
- 25mm buildout extension.
- 37mm buildout extension. (maximum).

16. CLOSING SYSTEM

Spring catch will be supplied as the standard.

Magnets are a **no charge option**.

17. SPECIAL INSTRUCTIONS

Eg: If 90° or 135° posts are required. Flexistrip or Flexiscribe etc.

PLEASE NOTE: Manufacturing tolerances are +/- 1mm.

HOW TO MEASURE

MEASURING TOOLS

Measuring stick/tape measure, spirit level, masking tape and pencil.

Shutter Samples: panels, frames, hinges etc, shutter folder, bay window templates.

MEASURING OF SQUARE WINDOWS (Inside and outside)

Measuring of rectangular windows. Inside recess for "L" Frames.

To check if the window is square, measure diagonally across the window from corner to corner in both directions. If these sizes differ by more than 10mm the use of a "Z" frame or outside mount would be recommended. See Fig 1.

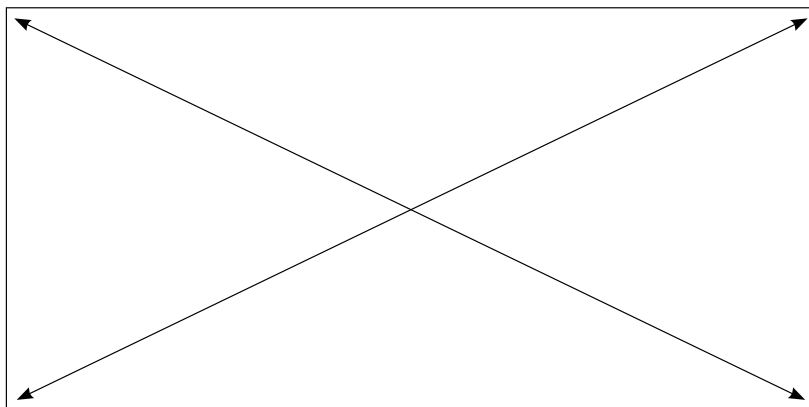

Fig 1.

If the window is suitable for an inside mount, check for any obstructions, e.g. window handles or vents, if these exist check the depth of the recess can fit the shutter without catching the obstructions whilst still being inside the recess.

Measure the width inside the recess at 3 points top middle and bottom.

Measure this height of the recess at 3 points left, centre and right. See Fig 2.

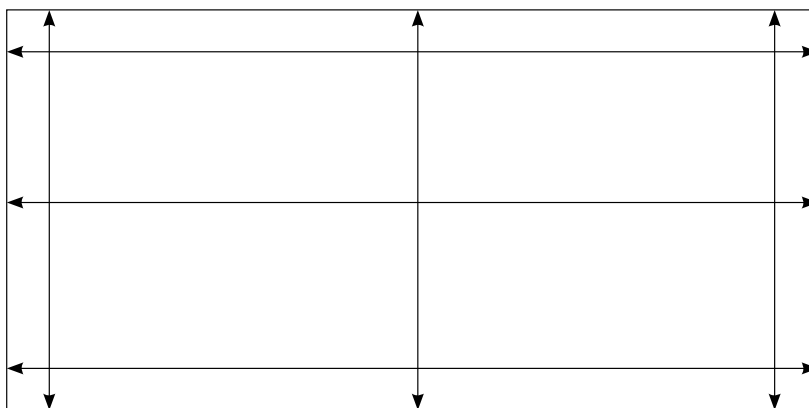

Fig 2.

Take the smallest size for width and height and deduct 3-10mm for clearance and manufacturing tolerances.

These sizes will be the finished size of the shutter frames. If the window is not square more may have to be deducted to allow the frame to be fitted square to the window and any gaps would require covering or filled with caulk. See Fig 3.

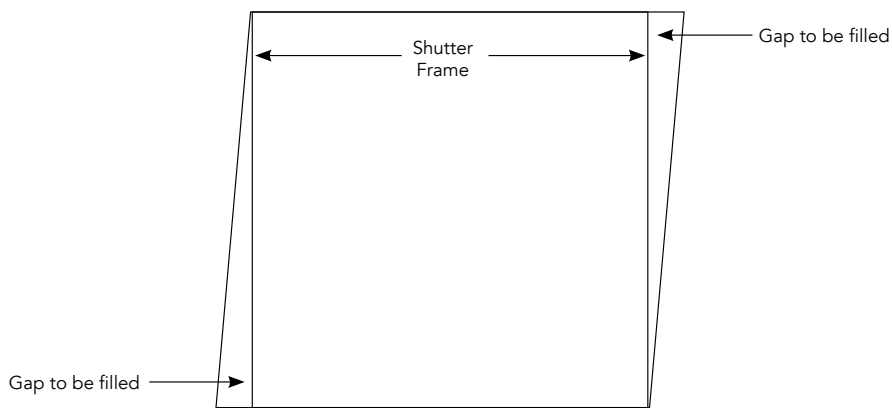

Fig 3.

MEASURING FOR MODA/CONTEMPO FRAMES

For Moda/Contempo frames, measure inside recess at the front of the recess or where the frame will be fitted. This is done in the same manner as for inside recess fitting. Choose this frame to best cover any gaps if the window is not square. For divider rail or transom measure from the window sill to the centre of the divider rail or the T-Post position.

MEASURING FOR OUTSIDE RECESS FIT (Classic Frame or Moda Multi L Frame)

Measure the width in 3 places, top, middle and bottom. Use the largest size and add on 25mm to each side to ensure a good substrate to fix to, add the width of the outer frames ensuring that the louvres do not hit any obstruction, if they do a buildout will be required either 12mm or 25mm. See Fig 4.

Measurement for Classic Frame = 114mm
 Measurement for Moda Multi L Frame = 56mm

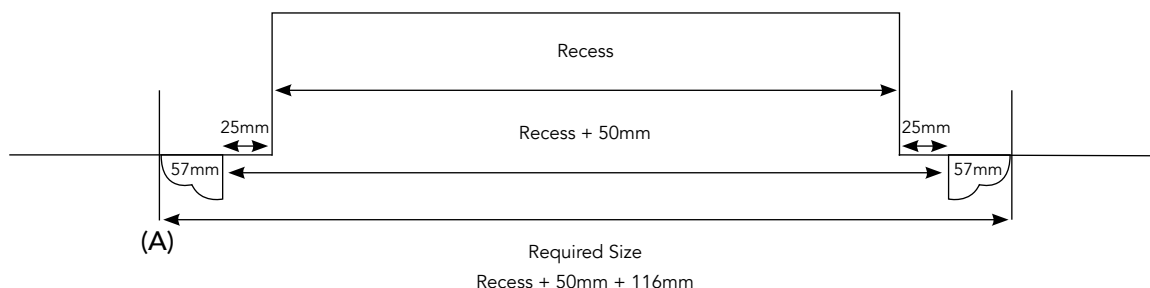

Fig 4.

For a 4 sided Classic and Moda Multi L Frame measure the width and drop in 3 places, left, centre, right, top, middle and bottom. Use the largest size and add 25mm to the top, bottom, left and right. The width of the frame being used e.g. Recess 1000 + 25 + 25 + 114 = 1164 drop.

For T-Post measure from the outside edge of where the frame would be fitted (A) to the centre of the T-post position.

For a divider rail if using a 3 sided frame, measure the width as previously described. Measure the drop in 3 places left, centre and right, use the largest measurement and add 25mm for the top only and the frame width at the top only. E.g. 1000 + 25 + 57 = 1082 drop. For a divider rail measure from the window sill to the centre of divider rail.

Please note: Maximum recommended sizes

Shutters outside of maximum recommended sizes cannot be guaranteed. It is also recommended that all shutters have a bottom to the frame - we cannot guarantee the doors will not drop if unsupported by a bottom frame.

MEASURING FOR 135° BAY WINDOWS (The best frame choice is Moda Multi)

There are two sets of templates one for 63mm and one for 89mm. These templates can be used for either fitting close to the window or allowing a 40mm projection for window handles.

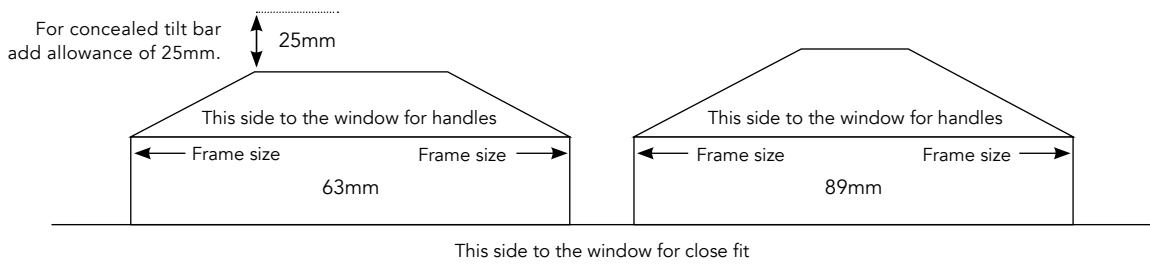

PLEASE NOTE: - 2mm off each shutter width when using Flexi bay cover strip for Moda Multi.

Choose the correct size templates for the slat. Use a spirit level to make sure the walls run level. If not mark a level point on the window sill. Place the templates on the window sill working from left to right. See Fig 1.

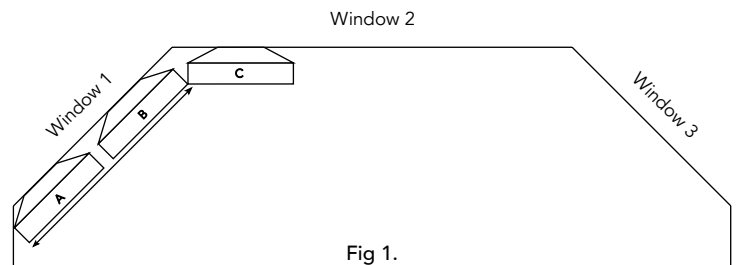

Measure from the outside edge of the template "A" to the outside of the template "B". This is the frame size for window No. 1.

Leaving templates "C" in position move templates "A" & "B" to the opposite end of window 2. See Fig 2.

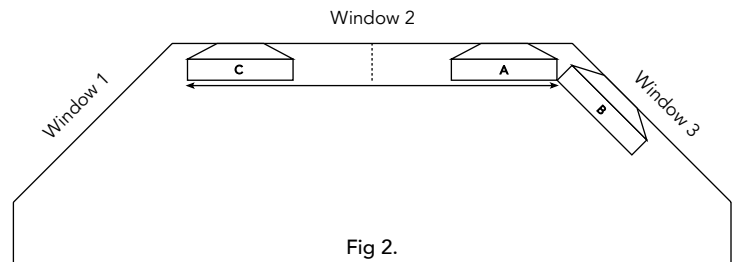

Measure from the outside edge template "C" to the outside edge template "A". This is the frame width for Window 2. If a T-Post is required measure from the outside edge of the Template "C" to the centre of the "T" post position.

Leaving template "A" & "B" in position move the template "C" to the opposite side of window 3. See Fig 3.

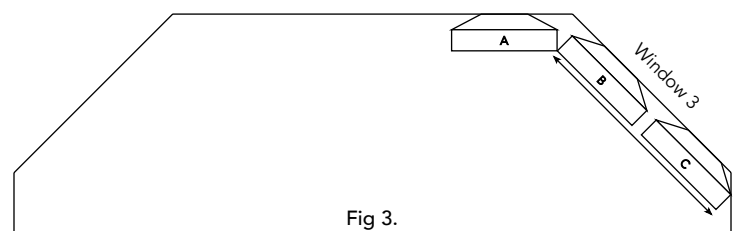

Measure from the outside edge of the template "B" to the outside edge of Template "C". This is the shutter frame size for window 3.

MEASURING CURVED BAY WINDOWS

For measuring a curved bay window follow the same process as for the 135° Bay and continue moving the templates from window to window.

MEASURING THE HEIGHT

Measure the height of the window at each side, each corner and the centre, take the smallest size and deduct at least 3mm. This will be the height of all 3 shutters and any gaps above or below the frame would require filling with caulk or a scribe strip.

BOX BAY WINDOWS

Box Bay Windows are measured in a similar way to angled bay windows using the same templates meeting at 90° in each corner. If the sides have window handles and an allowance is required buildouts would be required for the outer edge of each side shutter to cover any gapping. See Fig 1.

PLEASE NOTE: Manufacturing tolerances are +/- 1mm.

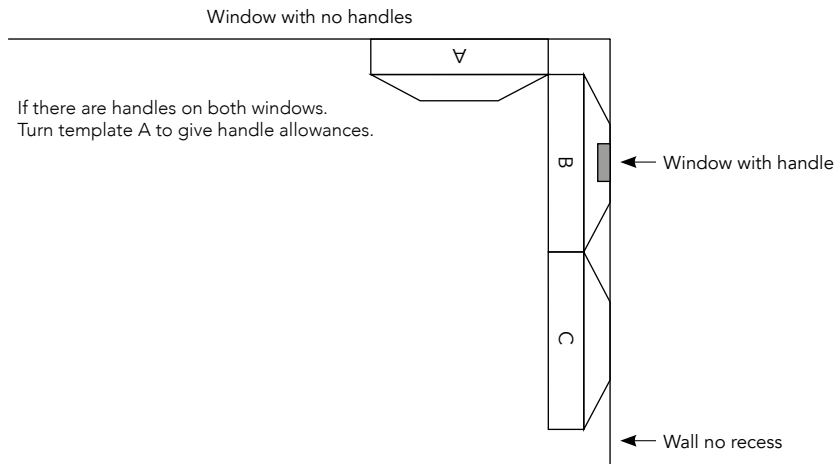

COMMON OBSTRUCTIONS

Window Handles

If window handle protrudes from the window frame measure the distance from the window frame to the front of the handle.

Dado / Picture Rails / Skirting Boards

It is preferable to remove obstruction and have shutter the full size. If this is not possible measure between the obstructions and deduct 2mm for shutter width. Any gaps would have to be filled with caulk or filler strip.

COMPONENT DIMENSIONS

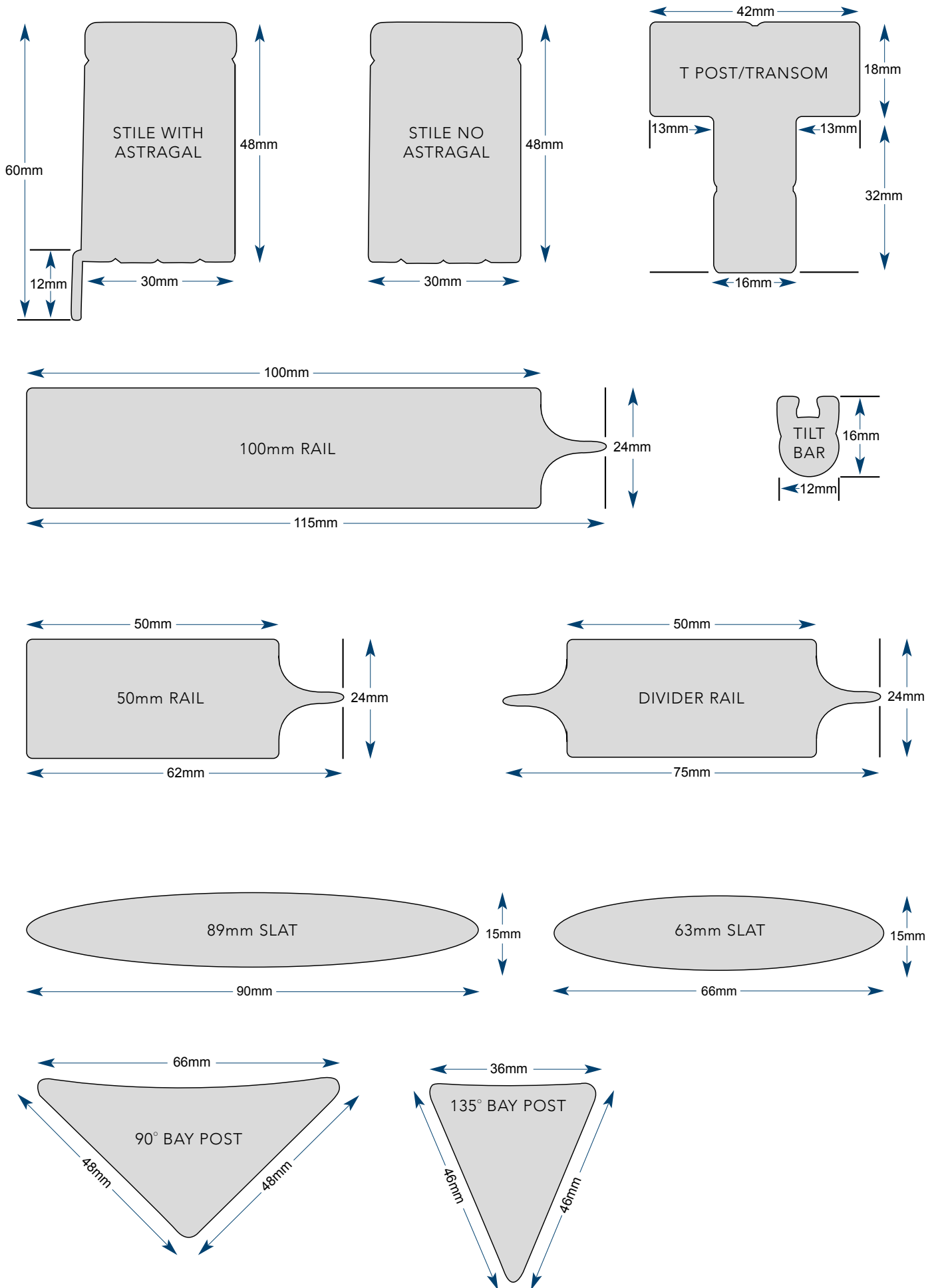

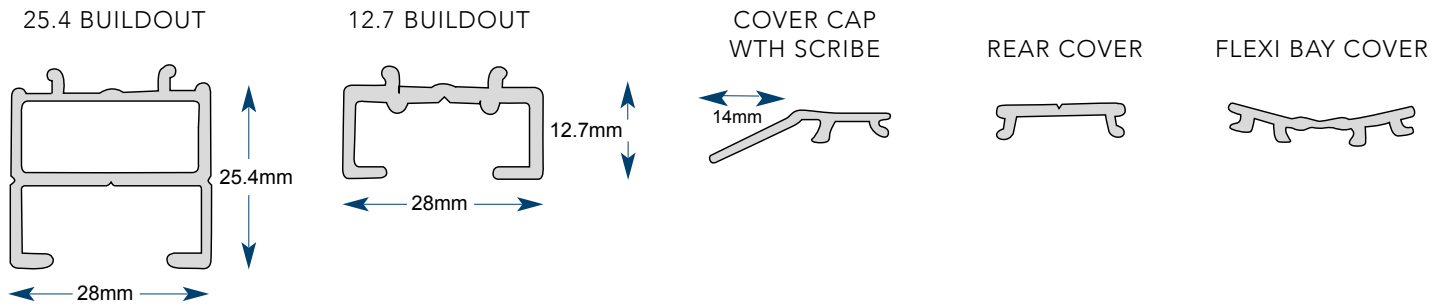

CUT LENGTH SERVICE

ITEM NUMBER	PRODUCT NAME	ROLL LENGTH
SH4050A	T-POST ALUMINIUM INSERT	2.5M
SH4052	BAY POST 45 DEGREE COTTON	3M
SH4053	BAY POST 90 DEGREE COTTON	3M
SH4063-ART-MATTE	RIGID SCRIBE STRIP 100MM ARCTIC	2.5M
SH4063-COT-MATTE	RIGID SCRIBE STRIP 100MM COTTON	2.5M
SH4064-ART-MATTE	REAR COVER STRIP ARCTIC	2.5M
SH4064-COT-MATTE	REAR COVER STRIP COTTON	2.5M
SH4065-ART-MATTE	FLEXI SCRIBE STRIP ARCTIC	2.5M
SH4065-COT-MATTE	FLEXI SCRIBE STRIP COTTON	2.5M
SH4067-ART	FLEXI BAY COVER ARCTIC	2.5M
SH4067-COT	FLEXI BAY COVER COTTON	2.5M
SH4068-ART-MATTE	12.5MM SQUARE BUILDOUT ARCTIC	2.5M
SH4068-COT-MATTE	12.5MM SQUARE BUILDOUT COTTON	2.5M
SH4069-ART-MATTE	25MM SQUARE BUILDOUT ARCTIC	2.5M
SH4069-COT-MATTE	25MM SQUARE BUILDOUT COTTON	2.5M
SH5000-ART-MATTE	63MM CONNECTOR LOUVRE CAP ARCTIC	Per 100
SH5005-ART-MATTE	63MM LOUVRE END CAP ARCTIC	Per 100
SH5010-ART-MATTE	89MM CONNECTOR LOUVRE END CAP ARCTIC	Per 100
SH5015-ART-MATTE	89MM LOUVRE END CAP ARCTIC	Per 100
SH5020-ART-MATTE	PVC TILT BAR CUFFLINK ARCTIC	Per 100
SH5030-ART-MATTE	STILE CAP ARCTIC	Per 100
SH5037-ART-MATTE	SPRING CATCH ARCTIC	Per 100
SH5040	MODA CORNER BRACKET	Per 100
SH5050-ART-MATTE	TILT BAR CAP ARCTIC	Per 100
SH5052-ART-MATTE	RAIL SCREW CAP ARCTIC	Per 100
SH5054-COT-MATTE	LOUVRE TENSION CAP COTTON	Per 100
SH5056	RAIL SCREW SUPPORT	Per 100
SH6020	MAGNETS	Per 100
SH6022	CORNER KEY	Per 100
SH6024	SILL ANGLE CORNER KEY	Per 100
SH6026	REMOVABLE HINGE	Per 50



URBAN SHUTTERS